

13539 / 75182

LEXUS RX 350 & RX 450h

5/15/2009

GROSS LOAD CAPACITY WHEN USED AS A WEIGHT CARRYING HITCH: 3,500 LBS. TRAILER WEIGHT & 350 LBS. TONGUE WEIGHT.
 GROSS LOAD CAPACITY WHEN USED AS A WEIGHT DISTRIBUTION HITCH: 4,000 LBS. TRAILER WEIGHT & 400 LBS. TONGUE WEIGHT

DO NOT EXCEED VEHICLE MANUFACTURER'S RECOMMENDED TOWING CAPACITY.

HAVING INSTALLATION QUESTIONS? CALL TECHNICAL SUPPORT AT 1-800-798-0813

Parts List			
ITEM	QTY	PART NUMBER	DESCRIPTION
1	6	M12-1.25 x 35mm	HEX BOLT
2	6	7/16"	CONICAL TOOTHED WASHER

RUBBER ISOLATOR REMOVAL DIAGRAM

This technique can be used if and Exhaust Hanger Removal Pliers is not available.

Using a 5/8" open end wrench, slide the wrench up to the rubber isolator, cradling the hanger rod as shown. Next place the flat edge of a pry bar between the wrench and the hanger stop or hanger rod. Then simply rotate the pry bar toward the wrench to remove the rubber isolator.

Note: Using a spray lubricant or soapy water on the hanger rod and the rubber isolator helps removal.

WELDNUT CLEANING

To remove debris from weldnuts in frame, spray lubricant or compressed air into hole. For heavy debris, use a small wire brush. (Be careful not to damage threads).

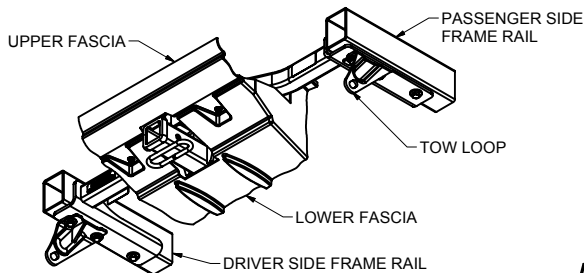

HITCH SHOWN IN PROPER POSITION

HITCH WEIGHT: 42 LBS.
 INSTALL TIME: 30 MINUTES
 INSTALL NOTES:
 - LOWER EXHAUST
 - FASCIA TRIMMING REQUIRED
 - NO DRILLING REQUIRED

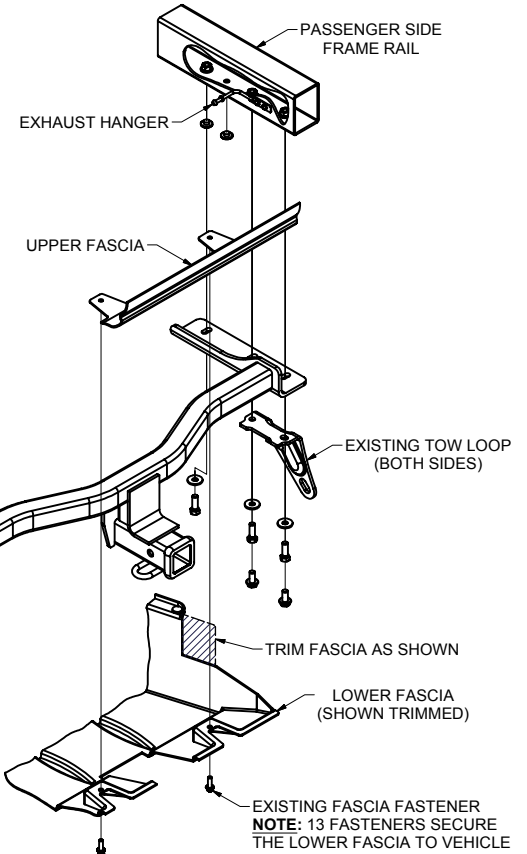
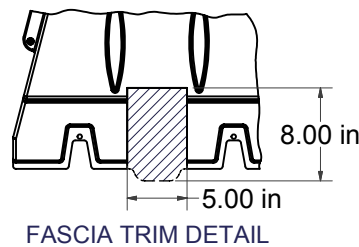

INSTALLATION STEPS

NOTE: Tow loop reattachment is optional.

1. Remove lower fascia. **NOTE: 13 fasteners secure the lower fascia to vehicle.**
2. Lower exhaust for ease of installation. Support exhaust as needed to prevent damage.
3. Remove existing hole plugs from frame rails as shown.
4. Remove existing tow loop fasteners and tow loops. Retain tow loops they will be reattached, return fasteners to owner.
5. Raise hitch and tow loops into position by aligning with existing weldnuts in frame.
NOTE: Hitch will be sandwiched between tow loops and frame rails.
6. Secure hitch and two loops with 12mm bolts and 7/16" conical toothed washers into existing weldnuts.
7. Torque all 12mm fasteners to 60 ft-lbs.
8. Reinstall exhaust
9. Trim lower fascia and reattach. (SEE FASCIA TRIM DETAIL)

PERIODICALLY CHECK THIS RECEIVER HITCH TO ENSURE THAT ALL FASTENERS ARE TIGHT AND THAT ALL STRUCTURAL COMPONENTS ARE SOUND.

Curt Manufacturing Inc., warrants this product to be free of defects in material and/or workmanship at the time of retail purchase by the original purchaser. If the product is found to be defective, Curt Manufacturing Inc., may repair or replace the product, at their option, when the product is returned, prepaid, with proof of purchase. Alteration to, misuse of, or improper installation of this product voids the warranty. Curt Manufacturing Inc.'s liability is limited to repair or replacement of products found to be defective, and specifically excludes liability for incidental or consequential loss or damage.